

Makita[®]

HR3200C

32mm SDS-Plus Rotary Hammer

240V



Product Overview

240V

Constant Speed Control

3-Mode Operation



Torque Limiter

Rubberised Soft Grip

High Performance 850W Motor

Variable Speed Dial

Product Specification Sheet

240V



Max Drill Capacity in Concrete	32mm
Max Drill Capacity in Wood	32mm
Max Drill Capacity in Steel	13mm
Impact Energy	5.5j
No Load Speed	315 - 630rpm
Impact Rate	1,650 – 3,300ipm
Vibration	18m/s ²
Noise	89dB
Continuous Rating Input	850W
Overall Length	398mm
Net weight	4.4kg
Power supply cord	5.0m

- **Constant Speed Control** – With a variable no-load speed of 315-630rpm, the onboard electronics will work to maintain power under load.
- **Torque Limiter** – If the HR3200C becomes seized the torque limiter will reduce power to protect the user.
- **3-Mode Operation** – The HR3200C features three modes, including rotation only, rotating and hammer, and hammer only.
- **Rubberised Soft Grip** – The rear handle of the tool is rubberised to enhance user comfort and control.
- **Variable Speed Dial** – The variable speed dial on the handle allows the user to better control the speed respective to the application and type of bit being used.
- **High Performance 850W Motor** – The HR3200C features an 850W motor for industrial applications.

Performance

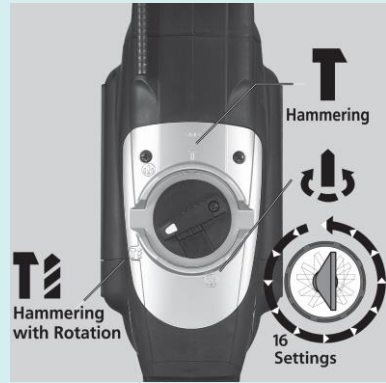

850W motor with 3-modes of operation

Comfort



5.5j of impact energy for drilling up to 32mm in concrete

Safety







Constant speed control with torque limiter

Control



Variable speed and rubberised soft grip

Standard Accessories		
	135197-7	Side Grip Assembly
	194683-7	Bit Grease 100ml
	-	Plastic Carrying Case

Optional Accessories		
	Link to Website	SDS-Plus Drill Bits

